

PCT

TRANSMITTAL LETTER TO THE UNITED STATES
DESIGNATED/ELECTED OFFICE (DO/EO/US)
CONCERNING A FILING UNDER 35 U.S.C. 371

0179-0170P

U.S. APPLICATION NO. (If known, see 37 CFR 1.5)

09/868845

INTERNATIONAL APPLICATION NO.

INTERNATIONAL FILING DATE

PRIORITY DATE CLAIMED

PCT/EP99/10142

JUN 21 2001

December 20, 1999

December 21, 1998

TITLE OF INVENTION

SCANNING MICROSCOPIC METHOD HAVING HIGH AXIAL RESOLUTION

APPLICANT(S) FOR DO/EO/US

MUELLER, Juergen Rolf

Applicant herewith submits to the United States Designated/Elected Office (DO/EO/US) the following items and other information:

1. This is a **FIRST** submission of items concerning a filing under 35 U.S.C. 371.
2. This is a **SECOND** or **SUBSEQUENT** submission of items concerning a filing under 35 U.S.C. 371.
3. This express request to begin national examination procedures (35 U.S.C. 371(f)) at any time rather than delay examination until the expiration of the applicable time limit set in 35 U.S.C. 371(b) and PCT Articles 22 and 39 (1).
4. The US has been elected by the expiration of 19 months from the priority date (Article 31).
5. A copy of the International Application as filed (35 U.S.C. 371(c)(2))
 - a. is transmitted herewith (required only if not transmitted by the International Bureau).
 - b. has been transmitted by the International Bureau. WO 00/37984
 - c. is not required, as the application was filed in the United States Receiving Office (RO/US).
6. An English language translation of the International Application as filed (35 U.S.C. 371(c)(2)).
 - a. is transmitted herewith.
 - b. has been previously submitted under 35 U.S.C. 154(d)(4)
7. Amendments to the claims of the International Application under PCT Article 19 (35 U.S.C. 371(c)(3)).
 - a. are transmitted herewith (required only if not transmitted by the International Bureau).
 - b. have been transmitted by the International Bureau.
 - c. have not been made; however, the time limit for making such amendments has NOT expired.
 - d. have not been made and will not be made.
8. An English language translation of the amendments to the claims under PCT Article 19 (35 U.S.C. 371(c)(3)).
9. An oath or declaration of the inventor(s) (35 U.S.C. 371(c)(4)).
10. An English language translation of the annexes of the International Preliminary Examination Report under PCT Article 36 (35 U.S.C. 371(c)(5)).

Items 11. to 20. below concern document(s) or information included:

11. An Information Disclosure Statement under 37 CFR 1.97 and 1.98-International Search Report (PCT/ISA/210) w/ documents
12. An assignment document for recording. A separate cover sheet in compliance with 37 CFR 3.28 and 3.31 is included.
13. A **FIRST** preliminary amendment.
14. A **SECOND** or **SUBSEQUENT** preliminary amendment.
15. A substitute specification.
16. A change of power of attorney and/or address letter.
17. A computer-readable form of the sequence listing in accordance with PCT Rule 13ter.2 and 35 U.S.C. 1.821-1.825.
18. A second copy of the published international application under 35 U.S.C. 154(d)(4).
19. A second copy of the English language translation of the international application under 35 U.S.C. 154(d)(4).
20. Other items or information:
 - 1.) Seven (7) sheets of Formal Drawings
 - 2.) PCT Request (PCT/RO/101)

U.S. APPLICATION NO (if known, see 37 CFR 1.5) 09/868845	INTERNATIONAL APPLICATION NO PCT/EP99/10142	ATTORNEY'S DOCKET NUMBER 0179-0170P
--	--	--

21. The following fees are submitted:

	CALCULATIONS	PTO USE ONLY
BASIC NATIONAL FEE (37 CFR 1.492(a)(1)-(5): Neither international preliminary examination fee (37 CFR 1.482) nor international search fee (37 CFR 1.445(a)(2)) paid to USPTO and International Search Report not prepared by the EPO or JPO.	\$1,000.00	
International preliminary examination fee (37 CFR 1.482) not paid to USPTO but International Search Report prepared by the EPO or JPO	\$860.00	
International preliminary examination fee (37 CFR 1.482) not paid to USPTO but international search fee (37 CFR 1.445(a)(2)) paid to USPTO.	\$710.00	
International preliminary examination fee (37 CFR 1.482) paid to USPTO but all claims did not satisfy provisions of PCT Article 33(1)-(4)	\$690.00	
International preliminary examination fee (37 CFR 1.482) paid to USPTO and all claims satisfied provisions of PCT Article 33(1)-(4)	\$100.00	
ENTER APPROPRIATE BASIC FEE AMOUNT =	\$ 860.00	
Surcharge of \$130.00 for furnishing the oath or declaration later than <input type="checkbox"/> 20 <input checked="" type="checkbox"/> 30 months from the earliest claimed priority date (37 CFR 1.492(e)).	\$ 130.00	
CLAIMS	NUMBER FILED	NUMBER EXTRA
Total Claims	21 - 20 =	1
Independent Claims	2 - 3 =	0
MULTIPLE DEPENDENT CLAIM(S) (if applicable)	None	+ \$270.00
TOTAL OF ABOVE CALCULATIONS =		\$ 1008.00
<input type="checkbox"/> Applicant claims small entity status. See 37 CFR 1.27. The fees indicated above are reduced by 1/2.	\$ 0	
SUBTOTAL =		\$ 1008.00
Processing fee of \$130.00 for furnishing the English translation later than <input type="checkbox"/> 20 <input type="checkbox"/> 30 months from the earliest claimed priority date (37 CFR 1.492(f)).	\$ 0	
TOTAL NATIONAL FEE =		\$ 1008.00
Fee for recording the enclosed assignment (37 CFR 1.21(h)). The assignment must be accompanied by an appropriate cover sheet (37 CFR 3.28, 3.31). \$40.00 per property	\$ 0	
TOTAL FEES ENCLOSED =		\$ 1008.00
	Amount to be: refunded	\$
	charged	\$

a. A check in the amount of \$ 1008.00 to cover the above fees is enclosed.

b. Please charge my Deposit Account. No. _____ in the amount of \$ _____ to cover the above fees. A duplicate copy of this sheet is enclosed.

c. The Commissioner is hereby authorized to charge any additional fees which may be required, or credit any overpayment to Deposit Account No. 02-2448.

NOTE: Where an appropriate time limit under 37 CFR 1.494 or 1.495 has not been met, a petition to revive (37 CFR 1.137(a) or (b)) must be filed and granted to restore the application to pending status.

Send all correspondence to:
Birch, Stewart, Kolasch & Birch, LLP or Customer No. 2292
 P.O. Box 747
 Falls Church, VA 22040-0747
 (703)205-8000

Date: June 21, 2001

By Donald J. Daley
 Donald J. Daley, #34,313

09/868815
PATENT

531 Rec'd PCT/EP 0179-0170P
21 JUN 2001

IN THE U.S. PATENT AND TRADEMARK OFFICE

Applicant: MUELLER, Juergen Rolf Conf.:
Int'l. Appl. No.: PCT/EP99/10142
Appl. No.: New Group:
Filed: June 21, 2001 Examiner:
For: SCANNING MICROSCOPIC METHOD HAVING HIGH AXIAL
RESOLUTION

PRELIMINARY AMENDMENT

BOX PATENT APPLICATION

Assistant Commissioner for Patents
Washington, DC 20231

June 21, 2001

Sir:

The following Preliminary Amendments and Remarks are respectfully submitted in connection with the above-identified application.

AMENDMENTS

IN THE SPECIFICATION:

Please amend the specification as follows:

Before line 1, insert --This application is the national phase under 35 U.S.C. § 371 of PCT International Application No. PCT/EP99/10142 which has an International filing date of December 20, 1999, which designated the United States of America and was published in English.--

FOCUS 5439360

IN THE CLAIMS:

Please amend the claims as follows:

Cancel claims 1 through 22 without prejudice or disclaimer and substitute therefore the following new claims:

23. (New) Method for optically detecting at least one entity consisting of molecules, molecule complexes, polymers, polymeric particles, particles built up from inorganic materials, vesicular structures, cells, bacteria and virus, whereby

- the at least one entity is arranged on and/or in a substrate (60), said substrate (60) preferably being arranged on a support (61) and having a refraction-index which is different from the one of an at least one component adjacent to the substrate (60),
- the at least one entity is scanned with a measuring volume (70) using at least one device being confocal or configured for multi-photon-excitation said device consisting of a first radiation source (10) and at least one first objective (33), thereby receiving measuring values of optical parameters which are processed by means of a signal processing for characterization of the at least one entity,
- the at least one entity substantially maintains its position with respect to the substrate (60) or the support (61) or both for the duration of the obtaining the measuring values,
- before and/or during the scanning process an auxiliary focus (71) is generated by means of at least one second radiation source (11) and a second objective (34), said auxiliary focus (71) is at least partly arranged on the interface (62) between substrate (60) and adjacent component or on another interface (62) having a defined spacial relation to said entity,

TOC60"5429960

- the radiation generated by the first radiation source (10) is collimated by a first optic (33) and the radiation generated by the second radiation source (11) is collimated by a second optic (31) being different from the first optic (33),
- a retroreflection from the auxiliary focus (71) is detected by a detector (21) having a confocal arranged diaphragm (51) or by a plurality of detectors (21,22) having diaphragms (51,52) being arranged in front of and/or behind the image plane, and along the optical axis of the objective (34) generating the auxiliary focus (71), said retroreflection is used for measuring the position of the interface (62) and, thus, for indirectly positioning the measuring volume (70), and
- the position of the auxiliary focus (71) relative to the measuring volume (70) is adjusted or adjustable in a defined manner.

24. (New) Method for optically detecting at least one entity consisting of molecules, molecule complexes, polymers, polymeric particles, particles built up from inorganic materials, vesicular structures, cells, bacteria and virus, whereby

- the at least one entity is arranged on and/or in a substrate (60), said substrate (60) preferably being arranged on a support (61) having a refraction-index which is different from the one of an at least one component adjacent to the substrate (60),
- the at least one entity is scanned with a measuring volume (70) using at least one apparatus being confocal or configured for multi-photon-excitation said apparatus consisting of a first radiation source (10) and at least one objective (32), thereby receiving measuring values of optical parameters which are processed by means of a signal processing for characterization of the at least one entity,

096644-0001

- the at least one entity substantially maintained its position in respect to the substrate (60) and/or the support (61) for the duration of the recording,
- before and/or during the scanning process an auxiliary focus (71) is generated by means of at least one second radiation source (11) and an optic (32), said auxiliary focus (71) is at least partly arranged on the interface (62) between substrate (60) and adjacent component or on another interface (62) having a defined spacial relation to said entity,
- the radiation generated by the first radiation source (10) is collimated by a first optic (33) and the radiation generated by the second radiation source (11) is collimated by a second optic (31) being different thereto,
- a retroreflection from the auxiliary focus (71) is detected by a detector (21) having a confocal arranged diaphragm (51) or by a plurality of detectors (21,22) having diaphragms (51,52) being arranged in front of and/or behind the image plane, and along the optical axis of the objective (32) generating the auxiliary focus (71) said retroreflection is used for measuring the position of the interface (62) and, thus, for indirectly positioning the measuring volume (70), and
- the position of the auxiliary focus (71) relative to the measuring volume (70) is adjusted or adjustable in a defined manner.

25. (New) Method according to claim 23 characterized in that the extent of the confocal detected volume of the auxiliary focus (71), in particular in direction of the respective optical axes of the objectives (32,34) is smaller than the extent of the measuring volume (70).

TOC060 549960

26. (New) Method according to claim 25 characterized in that the auxiliary focus (71) for obtaining a smaller extent of the confocal detective volume of the auxiliary focus (71) is generated by a second objective (34) having a numeric aperture which is larger than the numeric aperture of the first objective (32) used for generating the measuring volume (70).
27. (New) Method according to claim 25 characterized in that for obtaining the small extent of the confocal detected volume of the auxiliary focus (71) a smaller part of the numerical aperture of a common optic or the respective optics (32,34) is used for generating the measuring volume (70) than for generating the auxiliary focus (71).
28. (New) Method according to claim 25 characterized in that for obtaining the small extent of the confocal detected volume of the auxiliary focus (71) a confocal arranged diaphragm (51) is used at the detection of the auxiliary focus (71), said diaphragm (51) having a smaller opening than a confocal arranged diaphragm (50) used at the detection of the measuring volume (70).
29. (New) Method according to claim 23 characterized in that for indirectly positioning the measuring volume (70) the position of the auxiliary focus (71) relative to the interface (62) is moved preferably periodically substantially along the optical axis of the optic (34) generating the auxiliary focus (71), the intensity of the retroreflection in dependence on the movement of the detector (21) is registered and the position of the auxiliary focus (71) is readjusted in a manner that the intensity of the retroreflection reaches its maximum.

FOIA b 7 - Exempt

30. (New) Method according to claim 23 characterized in that for indirectly positioning the measuring volume (70) the position of the auxiliary focus (71) relative to the interface (72) is moved both, laterally to the optical axis of the optic (34) generating the auxiliary focus (71) and axially.
31. (New) Method according to claim 29 characterized in that the amplitude of the preferably periodical movement of the auxiliary focus (71) is smaller than or equal to the axial extent of the measuring volume (70).
32. (New) Method according to claim 23 characterized in that the intensity of the retroreflection is detected by means of at least two detectors (21,22) and the position of the interface (62) is determined by means of the distribution of the intensities detected by the detectors (21,22).
33. (New) Method according to claim 23 whereby the scatter-light-intensity and/or the scatter-light-intensity in dependence on the polarization and/or the fluorescence-intensity at at least one wavelength and/or the fluorescence-intensity in dependence on the polarization and/or the fluorescence-durability and/or molecular luminosity and/or Raman-scattering and/or luminescence are detected as optical parameters.
34. (New) Method according to claim 23 whereby mineral or organic substrates (60) in particular polymeric gels, polymeric particles built up from inorganic materials, vesicular structures, cells, bacteria and virus are used.
35. (New) Method according to claim 23 characterized in that entities and/or substrates (60) selected by means of the optical parameters are separated during or after the scanning process from the other entities and/or substrates (60).

FOIA b 7 - Exempt

36. (New) Use of the method according to claim 23 in the research of active ingredients, in the functional analysis of combinatoric-chemical or combinatoric-biological synthesis-products in the functional genom-analysis, in the evolutive biotechnology, in the diagnostics, in the proteom-analysis or the investigation of material.

37. (New) Apparatus for performing the method according to claim 23 for optically detecting at least one entity consisting of molecules, molecule complexes, polymers, polymeric particles, particles built up from inorganic materials, vesicular structures, cells, bacteria or virus, comprising

- at least one first radiation source (10) as well as at least one device being confocal or configured for multi-photon-excitation said device comprising a first objective (32) and at least one first detector (20) for detecting measuring values from the measuring volume (70),
- at least a second radiation source (11) as well as at least one further device comprising a second objective (34) and at least one second detector (21) for detecting a retroreflection from an auxiliary focus (71), said second detector (21) having a confocal arranged diaphragm (51), or a plurality of second detectors (21,22) for detecting a retroreflection from an auxiliary focus (71), said second detectors (21,22) having diaphragms (51,52) arranged in front of and/or behind the image plane, and along the optical axis of the second objective (34) generating the auxiliary focus (71),
- at least one device for positioning measuring volume (70) and auxiliary focus (71) relative to a substrate (60),
- a device for variably positioning the auxiliary focus (71) relative to the measuring volume (70),
- a first optic (33) collimating the radiation generated by the first radiation source (10), and

0986845-090701

- a second optic (31) being different from the first optic (33) collimating the radiation generated by the second radiation source (11).

38. Apparatus for performing the method according to claim 23 for optically detecting at least one entity comprising molecules, molecule complexes, polymers, polymeric particles, particles built up from inorganic material, vesicular structures, cells, bacteria or virus having

- at least one first radiation source (10) as well as at least one device being confocal or configured for multi-photon-excitation said device comprising an objective (32) and at least one first detector (20) for detecting measuring values from a measuring volume (70),
- at least one second radiation source (11) as well as at least one further device comprising the same objective (32) and a second detector (21) for detecting a retroreflection from an auxiliary focus (71), the second detector (21) having a confocal arranged diaphragm (51), or a plurality of second detectors (21,22) for detecting a retroreflection from an auxiliary focus (71), said second detectors (21,22) having diaphragms (51,52) arranged in front of and/or behind the image plane and along the optical axis of the objectives (32) generating the auxiliary focus (71),
- at least one device for positioning the measuring volume (70) and auxiliary focus (71) relative to the substrate (60),
- a device for relative positioning the auxiliary focus (71) relative to the measuring volume (70),
- a first optic (33) collimating the radiation generated by the first radiation source (10), and
- a second optic (31) different from the first optic (33) collimating the radiation generated by the second radiation source (11).

TOC60 543960

39. (New) Apparatus for performing the method according to claim 23 for optically detecting at least one entity consisting of molecules, molecule complexes, polymers, polymeric particles, particles built up from inorganic material, vesicular structures, cells, bacteria or virus having
- at least one first radiation source (10) as well as at least one device being confocal or made for multi-photon-excitation consisting of a first objective (32) and at least one first detector (20) for detecting measuring values from a measuring volume (70),
 - at least a second radiation source (11) as well as at least one further device comprising a same objective (32) and a second detector (21) for detecting a retroreflection from an auxiliary focus (71), said second detector (21) having a confocal arranged diaphragm (51), or a plurality of second detectors (21,22) for detecting a retroreflection from an auxiliary focus (71), said second detectors (21,22) having diaphragms (51,52) arranged in front of and/or behind the image-plane and along the optical axis of the second objectives (34) generating the auxiliary focus (71),
 - at least one device for positioning the measuring volume (70) and auxiliary focus (71) relative to a substrate (60),
 - whereby the auxiliary focus (71) is adjusted relative to the measuring volume (70) in a defined manner,
 - a first optic (33) collimating the radiation generated by the first radiation source (10), and
 - a second optic (31) being different from the first optic (33) collimating the radiation generated by the second radiation source (11).

094050 5433360

40. (New) Apparatus according to claim 37 characterized in that the device for positioning the measuring volume (70) and the auxiliary focus (71) relative to the substrate (60) comprises means for positioning the auxiliary focus (71) relative to the measuring (70).
41. (New) Apparatus according to claim 37 characterized in that the device for positioning the auxiliary focus (71) relative to the measuring volume (70) comprises means for adjusting the relative position of the objectives (32,34) to each other.
42. (New) Apparatus according to claim 37 characterized in that the device for positioning the auxiliary focus (71) relative to the measuring volume (70) comprises means for variation of the convergence of those bundles of rays that are focussed by the respective objective (32,34) for generation of the auxiliary focus (71) and the measuring volume (70).
43. (New) Use of the apparatus according to claim 37 in the research of active ingredients, in the functional analysis of combinatoric-chemical or combinatoric-biological syntheses-products, in the functional genon-analysis, in the evolutive biotechnology, in the diagnostics, in the proteon-analysis or the examining of material.

REMARKS

The specification has been amended to provide a cross-reference to the previously filed International Application. Entry of the present amendment and favorable action on the above-identified application are earnestly solicited.

Attached hereto is a marked-up copy of the changes made to the application by this Amendment.

If necessary, the Commissioner is hereby authorized in this, concurrent, and future replies, to charge payment or credit any overpayment to Deposit Account No. 02-2448 for any additional fees required under 37 C.F.R. § 1.16 or under 37 C.F.R. § 1.17; particularly, extension of time fees.

Respectfully submitted,

BIRCH, STEWART, KOLASCH & BIRCH, LLP

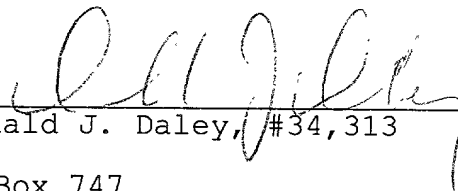
By 
Donald J. Daley, #34,313

P.O. Box 747
Falls Church, VA 22040-0747
(703) 205-8000

DJD/cqc
0179-0170P

Attachment: Version With Markings Showing Changes Made

FOIA b 7 - Exempt

09/868845

531 Res'd PCT 21 JUN 2001

Docket No. 0179-0170P

VERSION WITH MARKINGS SHOWING CHANGES MADE

The specification has been amended to provide cross-referencing to the International Application.

The claims have been amended as follows:

Claims 1 through 22 have been cancelled and new claims 23 to 43 have been added.

09/868845

Scanning-microscopic method having high axial resolution

The present invention relates to a method for optically detecting at least one entity on or in a substrate, preferably arranged on a support. Furthermore, fields of application of the method according to the invention as well as a device for carrying out said method are described.

5

It is known that confocal arrangements or arrangements being constructed for multi-photons-excitation due to their high axial local-resolution are suitable for reduction of background signals which are outside of the focal plane. Thus, in particular when detecting large-surface-structures, there is the problem that during the scanning process it has to be ensured that the focal plane is always situated in a desired position within the objects to be examined. Therefore it is possible that, for example, irregularities of a sample-support, the object to be examined is arranged on, lead to that the confocal measuring volume is not in the desired plane within the object but possibly detects structures adjacent said object, as for example parts of the sample-support. This adversely effects the object's registration and characterization that has to be performed. Therefore it is desired to take measures to maintain or to track the focal plane within a certain position.

09868845
090701

20 "Patent Abstracts of Japan" (vol. 018, no. 436 (P-1786), August 15, 1994) describes a device for detecting the focus-position suitable for automatically focussing an image-generating device or for measuring inequalities of the surface of an object to be examined. An optical fiber is used the end of which is moved along an optical axis by means of an actuator. The so produced
25 interfering signal is used for the detection of deviation of the focus-position as well as for readjustment of the same.

"Patent Abstracts of Japan" (vol. 098, no. 004, March 31, 1998) proposes a focus-detector using the principle of confocal microscopic optics.

30

US-A-5,062,715 discloses the use of a confocal autofocus system in a Michelson-interferometer designed for the measurement of surface-vibration.

5 US-A-5,084,612 describes an image generating method for a scanning-microscope constructed in transmission-geometry. Herein, the position of an apertured diaphragm used for detection is tracked in a manner that possible deviation of transmitted light occurring in proximity of (in the section of?) the sample because of refraction-effects are compensated. However, it is not the object of said method to track the position of the measuring focus within the
10 sample.

PCT/US95/01886 (international publication number WO 95/22058) describes a confocal detection device having an automatic focussing mechanism including a confocal apertured diaphragm. The autofocusing is realized in three steps.
5 First, a laser is focused on the back side of a substrate having the sample applied thereon. In a further step the focus is positioned in a plane above the substrate. It is only in a third step, that after passing the desired position on the surface of said substrate the exact position of the surface is determined and the focus is adjusted on the substrate-surface. This process is performed
10 at the four corners of the substrate which is an extremely time-consuming procedure. It is not possible to operate the autofocussing system during the actual measurement of the sample and the focus-height is estimated by interpolation. Hereby, not acceptable positioning defaults may occur, in particular with substrates which are not plan, as they are normally used in
25 laboratories for cost reasons.

Therefore, it is the object of the present invention to provide a method which allows a reliable detection of sheet-like or three-dimensional structures, preferably being arranged on a sheet-support, in a detection device with high
30 axial resolution, in particular a confocal microscope. Further, a device for carrying out the method shall be provided.

The object is solved by a method with the features according to claim 1 as well as by a device with the features according to claims 16 or 17.

5 The invention provides a method or a device for optically detecting at least one entity on and/or in a substrate, preferably being arranged on a support, whereby a representative portion of the substrate having the entity applied thereto is scanned with a measuring volume by means of at least one device being confocal or configured for multi-photon-excitation, thereby receiving measuring values of optical parameters. These measuring values are then
10 handled by means of signal processing for characterization of the at least one entity. During the time period of the recording of the measuring values the at least one entity substantially remains in its position in respect to the substrate and/or the support. The substrate has a refraction-index which is different from the one of the at least one component adjacent to the substrate. For
15 example, the adjacent component may be a support having the substrate applied thereon. However, the substrate may also directly abut to an immersion-fluid, to air or to a component covering the substrate, as for example a covering glass.

20 According to the invention an auxiliary focus is generated before and/or during the scanning process, the auxiliary focus being positioned at least partly on the interface between the substrate and the adjacent component or another suitable interface. This interface has a defined spatial relation to the entity. Thus, for example, the entity (for example macromolecules as proteins or
25 nucleic acid to be examined) could be embedded in a substrate (for example a gel) which is positioned on a support (for example a sample-support made of optical glass). It is the function of the auxiliary focus to determine the position of the interface and, in particular, to enable the detection of the distance between the interface and the optic generating the auxiliary focus. According
30 to the invention auxiliary focus and measuring volume have a defined position to each other that is adjustable by the user. Thus, it is possible to also track the position of the measuring volume relative to the interface by tracking the

position of the auxiliary focus. Thus, the distance of the measuring volume from the interface can be selected by the user.

5 By means of a confocally arranged detector the intensity of the light retroreflected by the interface is detected. Said intensity has a maximum value in case the auxiliary focus is positioned in direction of the optical axis of the interface. The intensity of the retroreflection decreases when the auxiliary focus is moved on the optical axis in the direction towards the substrate or the component adjacent to the substrate. Alternatively, a plurality of detectors
10 may be positioned along the optical axis of the optic generating the auxiliary focus, in front of and/or behind the image-plane, and the ratio of the detected intensities can be determined.

5 Thus, the invention is characterized in that the tracking preferably may be performed online during the entire measuring procedure and thereby, the measuring volume may always be guided in a defined plane with selectable distance from the interface. The sensitivity of the focussing device to deviations from the set-position is preferably higher than the corresponding sensitivity of the confocal measuring device as it is described as follows.
10

In a preferred embodiment the auxiliary focus is generated by means of the same optic also serving for generation of the measuring volume. It is even possible to use the same radiation source for the generation of auxiliary- and measuring focus. Such a radiation source emits, for example, light of different
25 wavelengths or polarization which is separated by suitable optical components and, thus, can be supplied to the respected ray paths.

To enable the desired positioning of the auxiliary focus and, thus, also indirectly of the measuring volume, before and/or during the scanning process
30 it is desirable to find out whether the position of the auxiliary focus from the interface deviates in the direction towards the substrate or in the direction towards the component adjacent to the substrate. According to the invention the following solutions are proposed.

In a first preferred embodiment the position of an auxiliary focus relative to the interface is varied substantively along the optical axis and the intensity of the retroreflection is registered depending on the movement (see Figures 1, 2, 3, 5 and 6). Hereby, for example, the focussing optic is movable upward and downward along the optical axis. However, it is also possible to move the substrate which is, for example, arranged on a support positionable directly or indirectly in z-direction. Furthermore, it is possible to vary the divergence of the ray-bundles serving for generation of the auxiliary focus. Preferably, the movement is performed periodically. The intensity detected by the confocal arranged detector will be raised each time when the distance between reflected interface and auxiliary focus is reduced. In turn, the intensity will be reduced when said distance is raised by the movement. Thus, it is detectable by the direction of movement leading to a raise or reduction of the detected intensity in which direction the position of the auxiliary focus deviates from the position of the interface and the deviation can be corrected, respectively.

Preferably, the amplitude of the movement has to be selected so that a simultaneous recording of measuring values from the measuring volume will not be disturbed. Thus, the amplitude of movement will normally correspond to the axial extent of the measuring volume or will be smaller than said extent. In the latter case, the extension of the confocal detected volume of the auxiliary focus - in particular in the direction of the respective optical axes of the objectives used for generation of auxiliary focus and measuring volume - should be smaller than the extent of the measuring volume. Such a small extent may preferably be provided in a manner such that the auxiliary focus is generated by means of an optic having a numeric aperture which is larger than the numeric aperture of the optic used for generation of the measuring volume. Alternatively, also merely a smaller part of the numeric aperture of a common optic or of the respective optics may be utilized for generation of the measuring volume than for the generation of the auxiliary focus. In a further variation a confocal arranged diaphragm is used at the detection of the

auxiliary focus, whereby the diaphragm comprises a smaller opening than a confocal arranged diaphragm used for the detection of the measuring volume.

5 In a second preferred embodiment, the position of the auxiliary focus relative to the interface is moved both, laterally to the optical axis of the optic generating the auxiliary focus and axially. The analysis of the retroreflection may be performed in a manner corresponding to that of the embodiment described before.

10 In the third preferred embodiment, the intensity of the retroreflection is detected by means of at least two detectors arranged along the optical axis. Therefore, the light of the auxiliary focus reflected from the interface is, for example, divided up on the detectors by means of semi-reflecting mirrors. Preferably, the detectors are arranged in different distances from the focusing optic, in particular in front of and behind the focal plane, so that - depending on the position of the auxiliary focus relative to the reflecting interface - different portions of the reflected intensity are detected by the detectors. Thus, it can be determined from the distribution of the intensity detected by the detectors in which direction the position of the auxiliary focus deviates from the position of the interface. This is exemplary shown in Figure 4.

15 For example, two detectors arranged at the same distance from the focal plane in front of and behind said plane, respectively, detect an intensity-ratio of 1:1, if the auxiliary focus is placed on the interface. According to the direction of deviation of the auxiliary focus from the interface the intensity detected by one of the detectors increases.

25 A so determined deviation of the auxiliary focus from the desired position is correctable in all embodiments by a corresponding tracking, which, if necessary, is superimposed the above described movement. Preferably, the auxiliary focus is tracked in a manner that it is positioned on the interface.

12050 "5489860

To make the apparatusive efforts as little as possible it is desired to generate the auxiliary focus with the same optic that also serves for generation of the measuring volume. In such an embodiment of the invention semi-reflecting mirrors, for example, may be utilized to concentrate the rays generating measuring volume or auxiliary focus, respectively, in front of the objective as well as to separate the detected radiation reflected from the measuring volume or auxiliary focus, respectively. If it is desired, for example, to arrange measuring volume and auxiliary focus in adjustable distance from each other substantially along the optical axis, it is useful to connect suitable optical elements (e. g. lenses, convex and concave mirrors) in front of the objective on the side opposite to the sample to generate two bundles of rays of different divergence or convergence, respectively, which are then focused from the objective to the measuring volume and to the auxiliary focus, respectively.

On the other hand an arrangement can be selected, wherein measuring volume and auxiliary focus are generated by means of separate optics. In this case, both of the optics are advantageously connected mechanically or are controllable in a manner such that a tracking of the auxiliary focus affects a respective tracking of the measuring volume. Also in this embodiment measuring volume and auxiliary focus may either fully or partly overlap, or they may be arranged spacially separate from each other. The positioning of auxiliary focus and measuring volume to each other may in this case be adjusted by means of adjusting the positions of said two objectives to each other.

It might be preferred to generate the excitation ray path both, for the measuring volume and for the auxiliary focus, by means of one single radiation source optionally capable of emitting radiation of different wave lengths. On the other hand, in particular in the case of spacial separation of measuring volume and auxiliary focus, it might be preferred to use two separate radiation sources. The radiation sources can be, for example, a laser, a light-emitting diode, filament- or electric discharge lamps. Suitable detectors known by a person skilled in the art are, for example, photodiodes of the Avalache-type or

other photodiodes as well as a photomultiplier. Means for single-photon-detection are preferred.

5 In a further embodiment of a method and apparatus according to the invention it is in particular advantageous to select an objective having a high numeric aperture, preferably higher than 0.9, and/or a small operating-distance for generating the measuring volume and/or the auxiliary focus. The selection of a smaller operating-distance, in particular smaller than or equal to one millimeter, is in particular favorable measuring the fluorescence in the
10 measuring volume. Absorption of the fluorescence-light taking place in the emission-trace of the rays reduces the counter rate per molecule, i.e., the fluorescence-intensity detected per molecule. In contrast to the expectation this effect apparently linearly or more than linearly affects the signal-noise-ratio, so that a small operating distance is of advantage.

5 Preferably, the scanning process may be performed as follows. A confocal microscope is used for optically detecting volume to be observed having a radiation source, preferably for generating an excitation-light, a dichroic mirror from which entering radiation of the radiation source is reflected, an arrangement of objective lenses comprising a mechanical aperture, whereby
10 said arrangement receives the radiation reflected by the dichroic mirror and focuses said radiation on the volume to be observed, and an observing-optic-arrangement receiving the radiation coming from the volume to be observed and passing through the dichroic mirror. Between the dichroic mirror and the
25 objective-lense-arrangement a reflection-mirror-arrangement is positioned preferably having a plan deflection-mirror on the objective side which is arranged oscillable around a standard-point-position. When the mirror on the objective side is oscillating the optical axes of the respective reflected excitation-light cross each other in a substantially common intersecting point
30 in the portion of the mechanical aperture of the objective-lens-arrangement. The oscillation axis of the mirror on the objective side corresponds to the intersecting line of the plane that is fixed by the deflection-mirror on the objective side with the plane extending through the common intersecting point

of the optical axes of the reflected radiation and perpendicular to the optical axis of the reflected radiation, when the deviation mirror on the objective side is situated in its standard-point-position. A corresponding device is known from PCT/EP97/03022 (international publication number WO 97/48001) the disclosure of which is incorporated herewith by reference. But also other methods known by persons skilled in the art may be used for deviation of the ray which is generated by the radiation source. Optionally, it is also possible to vary directly or indirectly the position of the substrate or of the used microscope-optic(s).

For example, diffused light intensities, fluorescence intensities at at least one wave-length, fluorescence intensities in dependence on the polarization, fluorescence durabilities and/or molecule luminosities are detectable as optical parameters. Thereby, it might be preferred, to determine molecule luminosities according to the method described in WO-A-98/16814. Therein it is described that intensity fluctuations of emitted radiation from particles being placed in a measuring volume are observed by means of a detector, whereby said method comprises the following steps: repeated measurement of the number of the photons per time-interval defined length; determination of a function, as for example a distribution function, of the number of photons per time-interval; and then determination of the function, as for example again a distribution function, of the specific particular luminosities based on the function of the number of photons per time interval. Also reference is made how the function of the number of photons can be processed or how, for example, instrumental parameters can be taken into consideration in an adequate manner. Physical properties of particles, especially particular luminosities, may also be determined as it is disclosed in PCT/EP98/06165. The method described therein comprises the following steps: repeated measurement of the duration of time segments between detected photons; determination of a function, e. g., a distribution function of the duration of said time segments; and then determination of a function of specific physical properties of the particles to be examined based on said function of duration of the time segments. In particular, in relation to experimentally determined and

theoretic function of the duration of the time segments a fitting process is proposed, whereby, with regard to the theoretic function, parameters of a spacial luminosity-function that is characteristic for the instrumental arrangement are taken into consideration. It is proposed to examine, e. g.,
5 fluorescence-polarization, fluorescence-intensities depending on wave length, fluorescence-durability, energy transfer etc. In a further embodiment it might be of advantage to determine a plurality of optical parameters to obtain an improved characterization of the entity. In particular, this can be performed by means of the method described in PCT/EP98/03505. The following method is
10 proposed therein: determination of intensity-fluctuations of emitted radiation from particles situated in a measuring volume by means of at least one detector; determination of intermediate statistical data comprising an at least two-dimensional statistic function based on said intensity-fluctuations; determination of information based on the intermediate statistical data. In the
15 last step, for example, the mutual occurrence of two properties at one particle can be examined. Reference is made to the disclosure of the mentioned published patent application, in particular in relation to the physical properties to be examined of the examining particles, their determination as well as the determination of the intermediate statistical data, the disclosure is
20 incorporated herewith by reference.

The method according to the invention and the apparatus used to perform said method are suitable, for example, for detecting optical parameters of entities
25 as molecules, molecule complexes, polymers, vesicular structures, of, e. g., built up particles of polymers or inorganic materials, cells, bacteria and virus. They can, for example, be arranged on mineral or organic substrates. In particular, said substrates may consist of polymeric gels, particles built up from polymeric or inorganic materials, vesicular structures , cells, bacteria and
virus.

30 In a further embodiment, a-priori-information of the distribution and/or structure of the entities and/or of the substrates are used in the signal processing. So it is possible, for example, to use bacteria or polymeric balls (so

called beads) as a substrate, on the surface or in the interior of which in particular entities of the same kind are arranged, respectively. In signal processing, it is often helpful, to take into consideration a-priori-information concerning the substrate to be examined, as for example the structure, the spacial extent, the arrangement, etc. of said substrate to be capable, by means of signal processing, in particular image processing, of identifying measuring values as belonging together. Further, it might be of advantage, to form mean values over the measuring values belonging to entities identified as equivalent or to evaluate said measuring values statistically in a different manner to form the characterization of the entities more significant. Methods of object-identification known in literature as, for example, Hough-Transformation, Template Matching and correlative methods can be used as methods for signal processing. Said methods are described in literature (see, for example, E. R. Davies, Machine Vision: Theory, Algorithms, Practicalities; Academic Press, London - San Diego, 2nd edition, 1997).

It is often desirable, to separate excellent entities and/or substrates from the other entities and/or substrates by means of certain optical parameters to subject them to a further analysis and/or processing. This separation can be performed by means of a suitable manipulator, as for example a pipette, a mechanical gripper etc. Especially suitable methods are, for example, described in WO-A-95/35492 the disclosure of which is incorporated herewith by reference. For example, the removal or separation, respectively, by means of electric potential- or field impulse, of pressure-difference-pulse or also of light-pressure-pulse is described therein. It is also possible to use a preferably piezo-controlled pump- or dispensation-system, respectively. In general it is helpful to detect the determined measuring values depending on the position of the measuring volume during the scanning process for automation of the separation process.

In particular, the method and the corresponding device can be used in the searching for additives, combinatorial chemistry, functional genom-analysis,

evolutive biotechnology, diagnostics, material examination or proteom-analysis.

5 In one embodiment of the method according to the invention, for example, bead-structures are used as substrate, said bead-structures are occupied by a plurality of entities of the same kind or comprise said entities. For example, said entities may be a result of a process of the combinatorial chemistry, whereby normally the actual structure of the entity is unknown. Preferably, the entities comprise detectable markers, as for example fluorescence-colors. This
10 variation has the advantage that it is not necessary that the reacting agents added later comprise detectable markers. Preferably, the substrates are arranged on a support, as for example microfilter-plates with a plurality of recesses or a sheet-like structure. In this embodiment the upper- or lower surface of the support may be used as a interface for tracking the auxiliary focus and the measuring volume. Reacting agents are added, the interaction of which with the entities are to be examined. In an embodiment, these reacting agents may also comprise detectable markers. Thereafter, the substrate is scanned, for example, to find potential binders of the reacting agents among the entities and/or to produce a chemical reaction. The bond between the
15 reaction agent and the entity may be characterized by means of the optical parameters described above in more detail. Complexes having desired properties between reacting agent and entity may be separated from the other entities or substrates, respectively, to subject them to further analysis and/or treatment. Preferably, the described method is applied in the search for
20 active ingredients.

In a further variation a cleavable linking structure is arranged between the substrate and the entities having a detectable marker applied thereto. Thus, for example, in a process of chemical syntheses cleavable linking structures
30 may be arranged on substrates, as polymeric beads, said linking structures are connected with fluorescence-colors to which the entities to be examined are synthesized thereafter, preferably in a combinatoric method. This variation has the advantage that after selection of beads carrying complexes with desired

properties between the reacting agents and the entity a separation of the color-marked entity may happen, said entity can be analyzed thereafter in a so-called dissolving assay. This variation is also in particular suitable for the searching of active ingredients.

5

In a further embodiment substrates with entities of known structure are used whereby all substrates comprise the same entities. Preferably, the substrates are also distributed on recesses of microtiter or nanotiter plates herein. Thereafter, a solution of reacting agents known to be interactive with the entities are added to the recesses. Further, solutions of active ingredients of different potential are added to the recesses to find out if said active ingredients are suitable to influence the interactivity between entity and reaction agent.

10

The above-described embodiments may also be performed with biological substrates as for example virus, phages, bacteria, fungals or eucaryotic cells. Thus, for example, natural or cloned entities can be examined preferably on the surface of said biological substrate with the advantage that here is a coupling between the as desirable identified phenotype with its corresponding genotype. Such a proceeding is known under the pertinent term of phage-display or cellular-display.

15

20

In a further application the method according to the invention may also be helpful in cellular reporting assays. The precision of the scanning method, in particular the exact local resolution, allows the observation of the exposure and/or intracellular translocation of substances having a surprising high local resolution as well as quantification-precision.

25

The method according to the invention allows also in an advantageous manner the examination of paths of signaltransduction. In particular it is also characterized in that it is possible to work with primary cells and thus, an upregulated expression of the entities to be examined, as for example receptors, can be renounced.

30

Furthermore, the method is applicable in the so-called differential display, wherein cells of effected persons can be compared with those of healthy persons. Further possibilities of comparison comprise: treated/untreated cells, wildtype/mutants, etc.

Further applications relate to examinations of molecular interactions, as for example protein-protein-interactivities and protein-nucleic-acid-interactivities. In particular, it is also possible to examine interactivities between proteins and peptides of unknown nature or function with ligandes of potential physiological significance, however, the structure of which is often not cleared up yet. Hereby, preferably at least one agent will be coupled chemically or adsorbedly with a particular structure.

It can also be preferred to apply the method according to the invention as well as the corresponding device in the field of gelelectrophoreses. In combination with the separation or isolation step, respectively, certain entities on the gel serving as a substrate can be directly directed to another analysis or also duplication (PCR, etc.).

The method and the device according to the invention are also applicable for detection and preferably for isolation of cell types rare to be found, as this is the case, for example, in the prenatal-diagnostics, in the oncology or in general in the pathology.

Preferred embodiments according to the invention are described in the following:

Figure 1 is a schematical view illustrating a confocal microscope arrangement having a radiation source and two detectors one of which detecting signals from the auxiliary focus and the other signals from the measuring volume.

Figure 2 is a schematical view illustrating another embodiment of a confocal microscope arrangement according to the invention, wherein measuring volume and auxiliary focus are arranged along the optical axis separately from each other. The arrangement includes an additional radiation source for generating the auxiliary focus.

Figure 3 is a variation, wherein separate optics are used for generation of auxiliary focus and measuring volume. As it is exemplary shown auxiliary focus and measuring volume are positionable separately from each other both in axial and lateral direction.

Figure 4 illustrates a further embodiment of the invention, wherein the auxiliary focus and measuring volume are anew generated by the same optic. In this variation two detectors being displaced from each other along the optical axes to detect the direction of deviation of the position of the auxiliary focus are used for the light that is reflected by the auxiliary focus.

Figure 5 shows an embodiment of the present invention, wherein the transition from a substrate to an adjacent air layer serves as a interface. Different sizes of auxiliary focus and measuring volume are obtained by different utilization of the numeric aperture of the used objective.

Figure 6 shows an embodiment with a fiber optic coupling.

Figures 7 a and b show the result of the experiences illustrated in example 2.

First of all, Figure 1 shows a confocal arrangement: The radiation from a radiation source 10 is collimated by an optic 33 and focused by an objective 32 on a substrate 60 to be examined. The radiation source 10 emits light of different wave lengths. Exchangeable optical means 35 having a refractive power dependent on the wave length separate said light in bundles of different convergence, said bundles are focused in different positions by the objective 32 thereby generating an auxiliary focus 71 and a measuring volume 70. Thus,

the desired distance between auxiliary focus 71 and measuring volume 70 is adjustable by the user by selecting the lens 35. In the illustrated exemplary arrangement the auxiliary focus 71 is situated on the interface 62 between substrate 60 and support 61, whereas measuring volume 70 is situated in the substrate 60. Scattered or fluorescent radiation emerging from the measuring volume 70 is bundled once again by the objective 32 and is fully or semi reflected by the beam splitter 40 being constructed, for example, as a mirror that is fully or semi reflecting. By an optic 30, the reflected radiation is focused on a diaphragm 50 arranged confocal with a measuring volume 70. The radiation passing through the diaphragm falls onto the detector 20 serving for receiving the measuring signals. The diaphragm 50 is not required when using multi-photon excitation.

By means of a further beam splitter 41, an optic 31 and a diaphragm 51 also arranged confocal, a part of the radiation from the auxiliary focus 71 reflected at the interface 62 is directed to the detector 21. In the arrangement according to present Figure the focusing optic 32, for example, is moved upward and downward along the optical axis to be able to determine the current position of the auxiliary focus 71 relative to the interface 62 and to readjust, if need be. Thus, an indirect follow up of the measuring 70 is ensured.

Figure 2 shows another variation of the confocal arrangement, wherein the measuring volume 70 and the auxiliary focus 71 are arranged along the optical axis separately from each other. The conventional confocal radiation- and detection unit consisting of radiation source 10, detector 20 and the corresponding optical elements has already been described in Figure 1. In this embodiment a separate radiation source 11 is used for generation of an auxiliary focus 71. In the shown example, the light of said radiation source reflected from beam splitter 42 is bundled to a converging beam by the optic 31, so that the auxiliary focus 71 generated by the objective 32 is positioned closer to the objective 32 than the measuring volume 70 resulting from focusing a parallel bundle of rays by means of the objective 32. The auxiliary

focus 71 again is arranged on the interface 62 between the substrate 60 and the support 61; the radiation reflected at the interface 62 is focused on the confocal arranged diaphragm 51 by means of the objective 32 and the optic 31 and detected by the detector 21. In this embodiment the auxiliary focus 71 can be arranged in a selectable distance from the measuring volume 70 by suitable positioning the optic 31. Preferably, the auxiliary focus 71 is positioned on the interface 62 and the measuring volume 70 is generated in a desired distance from an auxiliary focus 71 within the substrate 60. In a further embodiment the auxiliary focus 71 can be generated by a bundle of rays being divergent in front of the objective 32, thus, the auxiliary focus 71 is arranged in a greater distance from the objective 32 than the measuring volume 70. Advantageously, the searching-and adjusting mechanism described in Figure 1 can also be used in this embodiment.

Figure 3 shows a further embodiment according to the invention, wherein a separate objective 34 is applied for generation of the auxiliary focus 71. The measuring volume 70 is once again generated and imaged by the objective 32; the components of the conventional confocal arrangement arranged behind the objective 32 are already discussed in Figure 1. The positions of the objectives 32 and 34 are controllably or mechanically connected with each other. For generation of the auxiliary focus 71 a separate radiation source 11 is used, the radiation of which is collimated by an optic 35 and focused on the interface 62 between substrate 60 and support 61 by the objective 34. Radiation reflected from the auxiliary focus 71 is once again bundled by the objective 34 and reflected by the ray-divider 42. The reflected radiation is focused by an optic 31 on a diaphragm 51 confocal with the auxiliary focus 71; the radiation passing through the diaphragm 51 hits the detector 21. In the exemplary illustrated arrangement the auxiliary focus 71 and the measuring volume 70 are arranged separately from each other in axial as well as lateral direction. Advantageously, the searching- and adjusting mechanism described in Figure 1 can also be used in this embodiment.

Figure 4 shows a variation of the embodiment according to the invention shown in Figure 2, wherein two detectors 21,22 are applied for the light reflected by the auxiliary focus 71. Arrangements of two or more detectors can also be used for the embodiments according to Figure 1 or 3, respectively. The conventional arrangement for exposure to rays and observation of the measuring volumes 70 is executed as discussed in Figure 1. In the shown arrangement measuring volume 70 and auxiliary focus 71 are adjusted congruent. However, it is possible, to adjust other desired distances between measuring volume 70 and auxiliary focus 71 by positioning lenses 30 to 35 in a different manner.

The auxiliary focus 71 is once again located on the interface 62 between substrate 60 and support 61. The radiation reflected at the interface 62 is directed through the objective 32 and the radiation-divider 41 in direction to detectors 21,22. The radiation is divided on the detectors 21,22 by further ray-dividers 43. Both detectors are arranged in front of focusing optics 34,35 as well as diaphragms 51,52. The diaphragms 51,52 are thereby arranged in front or behind the confocal position, respectively, when the auxiliary focus 71 is placed on the interface 62. If now the relative position of auxiliary focus 71 and interface 62 to each other is changed, the detectors 21,22 will detect a changed intensity distribution of the retroreflexes. Dependent on the direction of the variation of position of the auxiliary focus 71 being displaceable in direction of the substrate 60 or the support 61 either a higher or a lower intensity of radiation originated from the auxiliary focus 71 will hit on the detector 21 or the detector 22. Thus, the searching movement described in Figure 1 is not required.

Figure 5 shows a further variation of the embodiment according to the invention illustrated in Figure 2. The conventional arrangement for radiation and observation of the measuring volumes 70 has already been discussed. In the exemplary shown arrangement measuring volume 70 and auxiliary focus 71 are adjusted congruent; however, their relative position to each other can be changed by suitable positioning of lens 31. Now, the transition between

substrate 60 and adjacent air 63 serves as interface 62. The optic 32 for generation of the measuring volumes 70 is only used partly concerning its numeric aperture. On the other hand there is a wide illumination on the optic 32 for generating the auxiliary focus 71. Likewise, imaging the measuring volume 70 on the confocal arranged diaphragm 50 and its corresponding detector 20 the numerical aperture of the detecting trace of the rays is limited by the diaphragm 53. This embodiment results in a smaller focus size of auxiliary focus 71 compared with the measuring volume 70. Thus, the amplitude of the searching movements of the auxiliary focus 71 described above can be selected so small that the receiving of measured values from the measuring volume 70 almost remains uninfluenced and, nevertheless, any deviations of the auxiliary focus 71 from the interface 62 can be detected and corrected.

Figure 6 shows a further embodiment of the optical arrangement for performing the inventive method according to Figure 2. The conventional arrangement for radiation and observation of the measuring volume 70 has already been discussed above. Preferably, a semiconductor laser, the output radiation of which is coupled in an optical fiber 81, is used for generation of the auxiliary focus 71. The optical fiber coupling 42 corresponds to the conventional ray-divider in Figure 2. In this embodiment the radiation of the auxiliary focus 71 is coupled in the core of an optical fiber 80 replacing the function of the apertured diaphragm 51 illustrated in Figure 2. After passing the optical fiber coupling 42 the radiation is directed on a detector 21 by an optical fiber 82. The optical fibers can be of single or multi mode types.

Figure 7 a shows theophylline-beads, mixed with antibodies mentioned in example 2. The high resolution shows that the locally raised concentration of fluorescent antibodies at the bead clearly differs from the background signal of the fluorescent antibodies being in solution. Figure 7 b shows the negative control without addition of the first antibody so that the second fluorescently marked antibody does not settle down at the bead and leads to the characteristic ring-structure in the picture.

In the following the invention is described in detail by the help of example 1 showing a specific embodiment of the method according to the invention as well as example 2 showing a concrete biological application.

Example 1

The present example substantially corresponds to the arrangement shown in Figure 6. A semiconductor laser 11 having a power of 3 mW and a wavelength of 780 nm is used as radiation source for generating the auxiliary focus 71. The output radiation of the laser 11 is directed to an optical fiber Y-coupling 42 by a monomode-glasfiber 81. Another monomode-glasfiber 80 at the exit of coupling 42 serves for supplying the radiation for the auxiliary focus 72 as well as for confocal detection of the light reflected at the interface 62.

An achromatic lens 31 having a focus of 40 mm serves for bundling the applied or detected radiation, respectively. The convergence of the ray bundles directed to the objective 32 and thereby the position of the auxiliary focus 71 relative to the measuring volume 70 can be varied by changing the distances between the free end of the fiber 80 and the achromatic lens 31. In the described embodiment the distance between measuring volume 70 and auxiliary focus 71 is adjustable from 0 to 100 μm by a displacement of the achromatic lens 31 by 5 mm.

The objective 32 used herein is a standard-microscope-objective having a 40-times magnification and a numerical aperture of 1.2. It is mounted on a piezoelectrical translator enabling a displacement of the objective over a distance of 100 μm from the optical axis. Conditional on the driving force of the translator as well as on the mass of the objectives used herein the limit frequency for this movement is about 400 Hz.

In this exemplary embodiment the transition from a glass support 61 (refraction index $n_1 \approx 1.52$) to the substrate 60, in this case consisting of an

aqueous suspension of polymeric balls (refraction index $n_2 \approx 1.33$), is used as contact a surface 62. The radiation reflected from the interface 62 is directed over the objective 32 and the achromatic lens 31 once again on the fiber 80 the optical core of which taking over the function of the apertured diaphragm 51 shown in Figures 1 to 5, thus, ensuring a confocal detection. Over the coupling 42 50% of the radiation capacity reaches the detector 21 consisting of a cilium-photodiode with downstream transimpedanz amplifier (amplification 10^8 v/a). The output signal of the detector 21 is supplied to a digital signal processor (DSP) by a 14-bit analog-digital-converter. Said DSP also controls the piezoelectrical translator of the objective 32 over a 14-bit digital-analog-converter and a downstream high voltage amplifier. For controlling the tracking the objective is moved upward and downward sinusoidally with a typical frequency of 200 Hz and an amplitude of $0,5 \mu\text{m}$. Over demodulation of the intensity received by the detector 21, said demodulation being synchronous to said searching movement, the DSP determines the direction of a possible deviation between the position of the interface 62 and the position of the auxiliary focus 71 (taking the temporal mean over the sinusoidal movement). The determined deviation is compensated by a tracking of the objective 32, said tracking interfering the sinusoidal movement.

In the confocal measuring apparatus an active quenched Avalanche photodiode is used for as detector 20. The hole-diaphragm 50 has a diameter of $50 \mu\text{m}$. A He-Ne-laser having an output wavelength of 543 nm, whose light capacity is reduced to $100 \mu\text{W}$, serves as radiation source 10.

Example 2

In the present example so called tenta-gelTM - beads of the type S PHB-Gly (RAPP polymers) are used for the substrate. Those are conjugated with theophylline-molecules (Aldrich) as entities. The charging of the beads is 9%. 5 mg of the beads are suspended in $444 \mu\text{l}$ PBS-puffers. Lab-tek chambered coverglasses, #1 borosilicate, septic, 8-well (Nunc Nalge International, Lot. No. 148116-0605) are used as sample supports. A polyclonal rabbit anti-

theopyllin-antibody (Europa Research, Lot. No. 80 17 15) is used as first antibody. A fluorescently marked (TRITC, Tetra-methylrhodamine-5-(and 6)-isothiocyanate) anti-rabbit-IgG-antibody (DAKO, Lot. No. 077(101)) serves as second antibody. The assay buffer, called TNT in the following, consists of: 50 mM Tris-HCl pH 7,5, 100 mM NaCl, 0,01% Tween-20.

The assay is done as follows: 8 μ l bead suspension are mixed with 100 μ l of a 1:2000 dilution of the first antibody and shaken for 30 minutes at room temperature. After that, the twice repeated washing step with TNT-buffer (0,01% Tween-20) is carried out. 100 μ l of a dilution 1:5000 of the second antibody are added and shaken for one hour at room temperature. After that, 200 μ l TNT-buffer are added.

A HeNe-laser with an emission wave length of 543 nm is used for generation of the trace of the rays of excitation with regard to the measuring volume 70. As a band filter suitable for the fluorescence-spectrum of TRITC a band pass on the side of detection is used having a mid-transition-wavelength of 580 nm and a half-intensity-width of 30 nm.

The result of example 2 is illustrated in Figures 7 a and b. The taken measuring values are first subjected to an image processing step serving for identification and localization of the single beads. To this the Hough-transformation is used in the described embodiment. Following, for each identified bead those measuring values are determined, which mark points on the bead-surface. To this, it is advantageously to use a-priori-information as in this case the expectation, that the optical cuts through the bead-surface lead to almost circular structures. In the present case, the measuring values of maximal intensity are determined along the searching paths extending radial from the center of the identified beads, respectively. Alternatively, the methods known from literature as edge-reinforcement and/or threshold-analysis may be used in this step.

CLAIMS

1. Method for optically detecting at least one entity whereby
- the at least one entity is arranged on and/or in a substrate (60), said substrate (60) preferably being arranged on a support (61) and having a refraction-index which is different from the one of an at least one component adjacent to the substrate (60),
 - the at least one entity is scanned with a measuring volume (70) using at least one device being confocal or configured for multi-photon-excitation said device consisting of a radiation source (10) and at least one objective (32), thereby receiving measuring values of optical parameters which are processed by means of signal processing for characterization of the at least one entity,
 - the at least one entity substantially maintains its position with respect to the substrate (60) or the support (61) or both for the duration of the obtaining the measuring values,
 - before and/or during the scanning process an auxiliary focus (71) is generated by means of at least one second radiation source (11) and an objective (34), said auxiliary focus (71) is at least partly arranged on the interface (62) between substrate (60) and adjacent component or on another interface (62) having a defined spacial relation to said entity,
 - a retroreflection from the auxiliary focus (71) is detected by a confocal arranged detector (21) or a plurality of detectors (21,22) being arranged in front of and/or behind the image-plane and along the optical axis of the optic (34) generating the auxiliary focus (71), said retroreflection is used for measuring the position of the interface (62) and, thus, for indirectly positioning the measuring volume (70), and
 - the position of the auxiliary focus (71) relative to the measuring volume (70) is adjusted or adjustable in a defined manner.

0986845.0001
FD/060" 5488860

2. Method according to claim 1 characterized in that the auxiliary focus (71) is generated by means of the same radiation source (10) and/or the same objective (32) which also serves for generating the measuring volume (70).
3. Method according to claim 1 or 2 characterized in that the extent of the confocal detected volume of the auxiliary focus (71), in particular in direction of the respective optical axes of the objectives (32,34) is smaller than the extent of the measuring volume (70).
4. Method according to claim 3 characterized in that the auxiliary focus (71) for obtaining a smaller extent of the confocal detected volume of the auxiliary focus (71) is generated by an optic (34) having a numeric aperture which is larger than the numeric aperture of the optic (32) used for generating the measuring volume (70).
5. Method according to claim 3 characterized in that for obtaining the small extent of the confocal detected volume of the auxiliary focus (71) the smaller part of the numerical aperture of a common optic or the respective optics (32,34) is used for generating the measuring volume (70) than for generating the auxiliary focus (71).
6. Method according to claim 3 characterized in that for obtaining the small extent of the confocal detected volume of the auxiliary focus (71) a confocal arranged diaphragm (51) is used at the detection of the auxiliary focus (71), said diaphragm (51) having a smaller opening than a confocal arranged diaphragm (50) used at the detection of the measuring volume (70)
7. Method according to claim 1 characterized in that for indirectly positioning the measuring volume (70) the position of the auxiliary focus (71) relative to the interface (62) is moved preferably periodically substantially along the optical axis of the optic (34) generating the auxiliary focus

0968845-09071
T02060 5488860

(71), the intensity of the retroreflection in dependence on the movement of the detector (21) is registered and the position of the auxiliary focus (71) is readjusted in a manner that the intensity of the retroreflection reaches its maximum.

8. Method according to claim 1 characterized in that for indirectly positioning the measuring volume (70) the position of the auxiliary focus (71) relative to the interface (72) is moved both, laterally to the optical axis of the optic (34) generating the auxiliary focus (71) and axial.
9. Method according to claim 7 or 8 characterized in that the amplitude of the preferably periodical movement of the auxiliary focus (71) is smaller than or equal to the axial extent of the measuring volume (70).
10. Method according to claim 1 characterized in that the intensity of the retroreflection is detected by means of at least two detectors (21,22) and the position of the interface (62) is determined by means of the distribution of the intensities detected by the detectors (21,22).
11. Method according to claim 1 whereby the scatter-light-intensity and/or the fluorescence-intensity in dependence on the polarization and/or the fluorescence-intensity at at least one wavelength and/or the fluorescence-intensity in dependence on the polarization and/or the fluorescence-durability and/or molecular luminosity and/or Raman-scattering and/or luminescence are detected as optical parameters.
12. Method according to claim 1 whereby mineral or organic substrates (60) in particular polymeric gels, polymeric particles built up from inorganic materials, vesicular structures, cells, bacteria and virus are used.
13. Method according to claim 1 whereby molecules, molecule-complexes, polymers, polymeric particles, particles built up from inorganic material, vesicular structures, cells, bacteria and virus are used as entities.

14. Method according to claim 1 whereby entities and/or substrates (60) selected by means of the optical parameters are separated during or after the scanning process from the other entities and/or substrates (60).
15. Method according to claim 1 for use in the research of active ingredients, in the functional analysis of combinatoric-chemical or combinatoric-biological synthesis-products, in the functional genom-analysis, in the evolutive biotechnology, in the diagnostics, in the proteom-analysis or the investigation of material.
16. Apparatus for performing the method according to claim 1 comprising
 - at least one first radiation source (10) as well as at least one device being confocal or configured for multi-photon-excitation said device comprising an objective (32) and at least one first detector (20) for detecting measuring values from the measuring volume (70),
 - at least one second radiation source (11) as well as at least one further device comprising an objective (34) and at least one second detector (21) for detecting a retroreflection from an auxiliary focus (71) whereby a confocal arranged second detector (21) or a plurality of detectors (21,22) being arranged in front of and/or behind the image plane and along the optical axis of the optic (34) generating the auxiliary focus (71) are used,
 - at least one device for positioning measuring volume (70) and auxiliary focus (71) relative to a substrate (60), and
 - a device for variably positioning the auxiliary focus (71) relative to the measuring volume (70).
17. Apparatus for performing the method according to claim 1 comprising
 - at least one first radiation source (10) as well as at least one device being confocal or configured for multi-photon-excitation said device comprising an objective (32) and at least one first detector (20) for detecting measuring values from a measuring volume (70),

09868845 09001
T02060 5488860

- at least one second radiation source (11) as well as at least one further device comprising an objective (34) in at least one second detector (21) for detecting a retroreflection from an auxiliary focus (71) whereby a confocal arranged second detector (21) or a plurality of detectors (21,22) arranged in front of and/or behind the image-plane and along the optical axis of the objective (34) generating the auxiliary focus (61) is used,
 - at least one device for positioning of measuring volume (70) and auxiliary focus (71) relative to the substrate (60),
 - whereby the auxiliary focus (71) is adjusted relative to the measuring volume (70) in a defined manner.
18. Apparatus according to claim 16 characterized in that the device for positioning the measuring volume (70) and the auxiliary focus (71) relative to the substrate (60) comprises means for positioning the auxiliary focus (71) relative to the measuring volume (70).
19. Apparatus according to one of the claims 16 or 18 characterized in that the same first radiation source (10) and/or objective (32) is used for generation of the measuring volume (70) and the auxiliary focus (71).
20. Apparatus according to claim 16 characterized in that the device for positioning the auxiliary focus (71) relative to the measuring volume (70) comprises means for adjusting the relative position of the objectives (32,34).
21. Apparatus according to claim 16 characterized in that the device for positioning the auxiliary focus (71) relative to the measuring volume (70) comprises means for variation of the convergence of those ray bundles being focussed by the respective objective (32,34) for generating the auxiliary focus (71) and the measuring volume (70).

0988845-090701
"0000"488800

22. Use of the apparatus according to claim 16 in the research of active ingredients, the functional analysis of combinatoric-chemical or combinatoric-biological synthesis-products, the functional genom-analyses, the evolutive biotechnology, the diagnostics, the proteom-analyses or in the investigation of material.

0986848 5489860

SUMMARY

The invention relates to a method for optically detecting at least one entity which is arranged on and/or in a substrate (60) preferably being arranged on a support (61), said substrate (60) having a refraction-index which is different from the one of the at least one component adjacent to the substrate (60). The at least one entity is scanned with a measuring volume (70) using at least one radiation source (10) and a confocal optic (32) or an optic (32) made for multi-photon-excitation, thereby receiving measuring values of optical parameters which are processed by means of signal processing for characterization of the at least one entity. Said entity substantially maintains its position in respect to the substrate (60) or the support (61) for the duration of the recording. Before and/or during the scanning process an auxiliary focus (71) is generated by means of at least one radiation source (11) and an optic (34), said auxiliary focus (71) is at least partly arranged on the interface (62) between substrate (60) and adjacent component or on another interface (62) having a defined spacial relation to said entity. A retroreflection from the auxiliary focus is detected by at least one detector (21) and is used for measuring the position of the interface (62) and, thus, for indirectly positioning the measuring volume (70). In the method according to the invention, the position of the auxiliary focus (71) relative to the measuring volume (70) is adjustable in a defined manner. Thus, possible applications of the method as well as an apparatus for performing said method are described.

1202050 "5488860

5

10

5

10

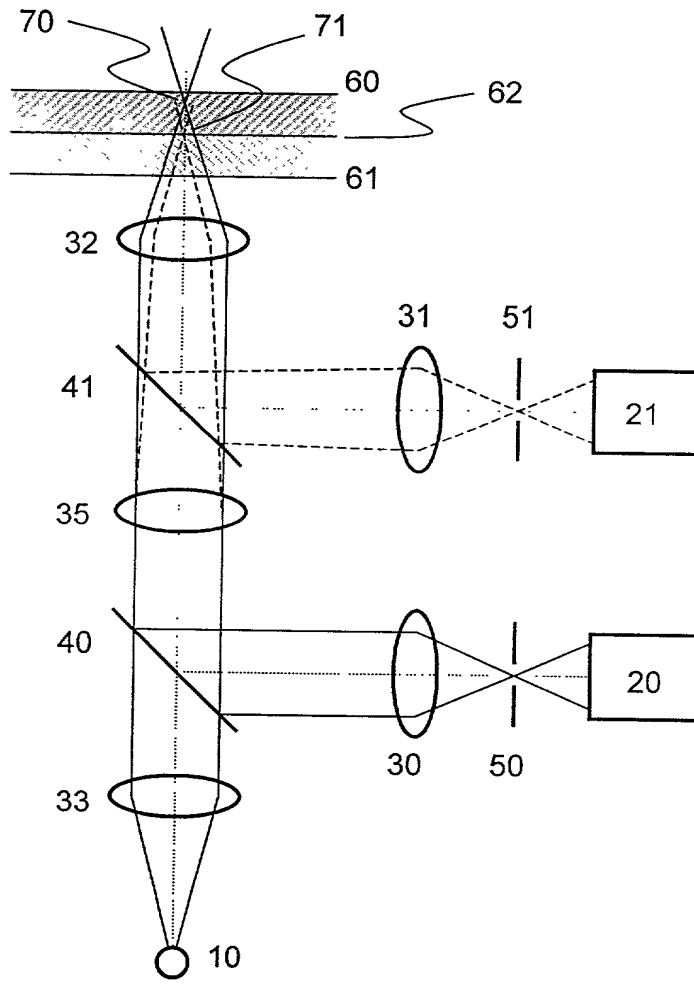

Figur 1

09868845

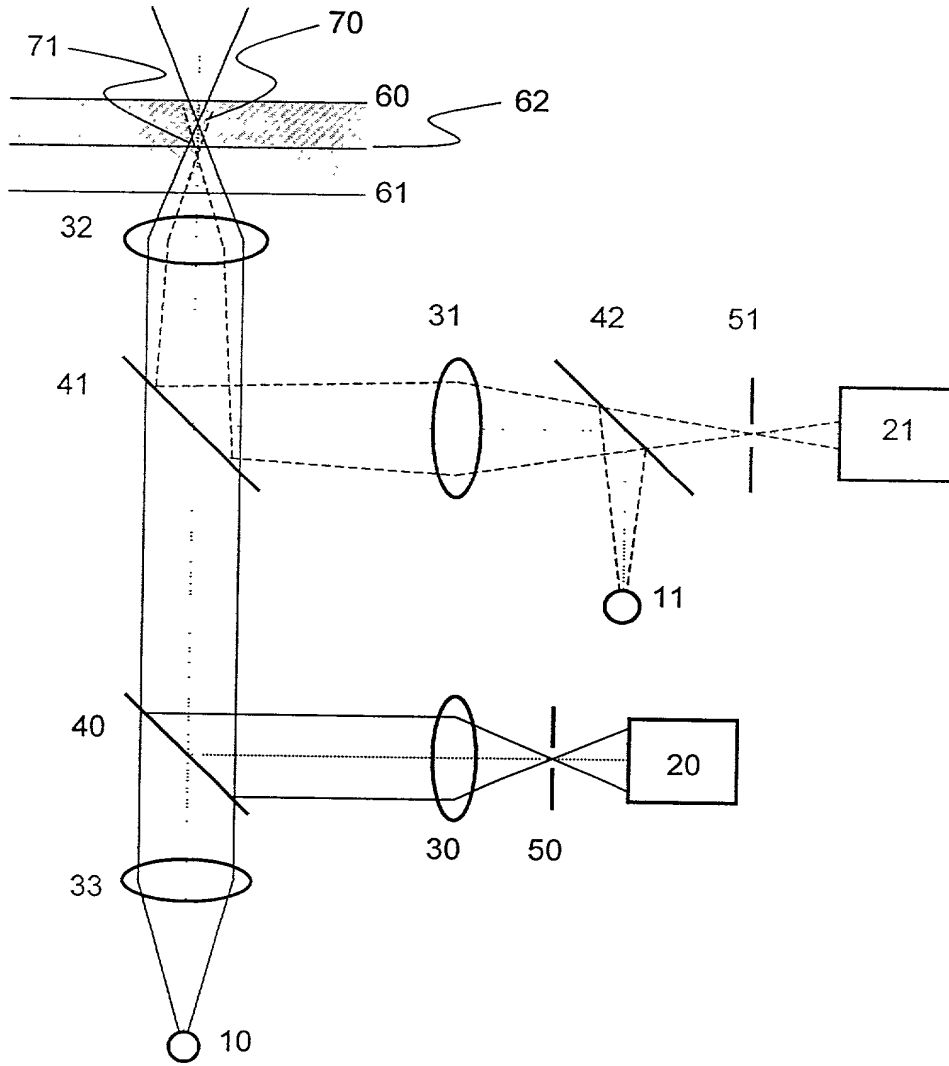

Figur 2

09868845

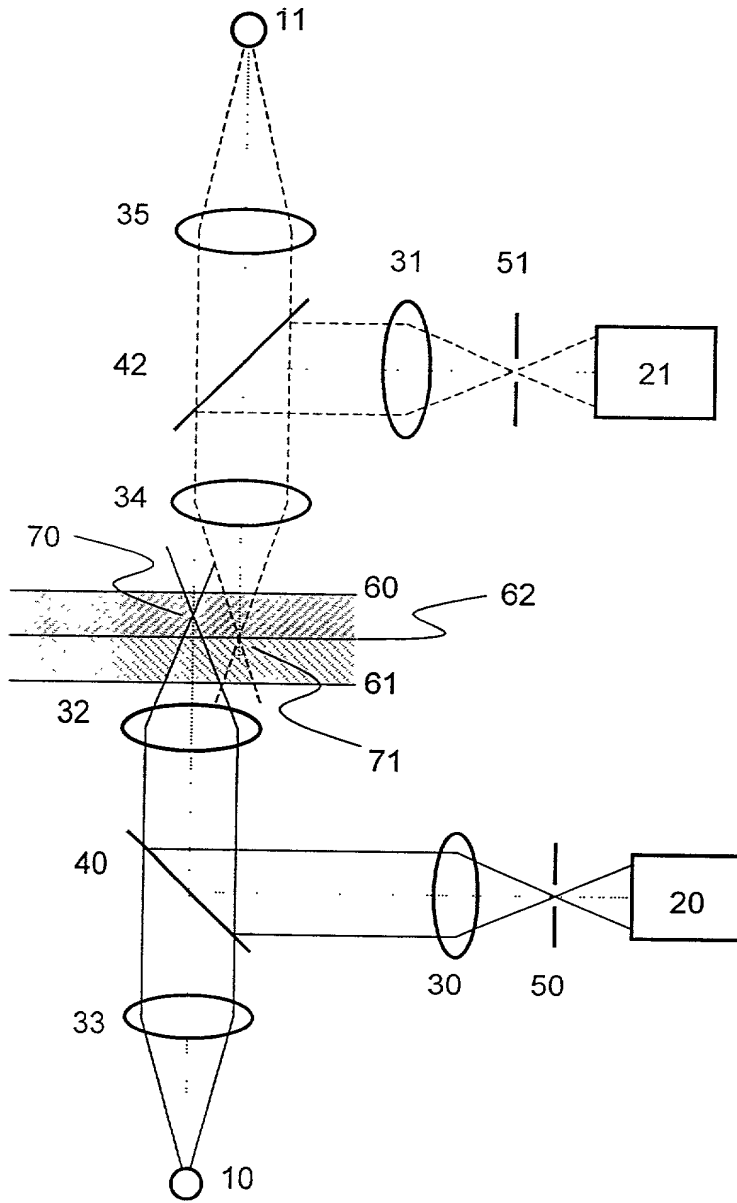

Figur 3

09868845-00001

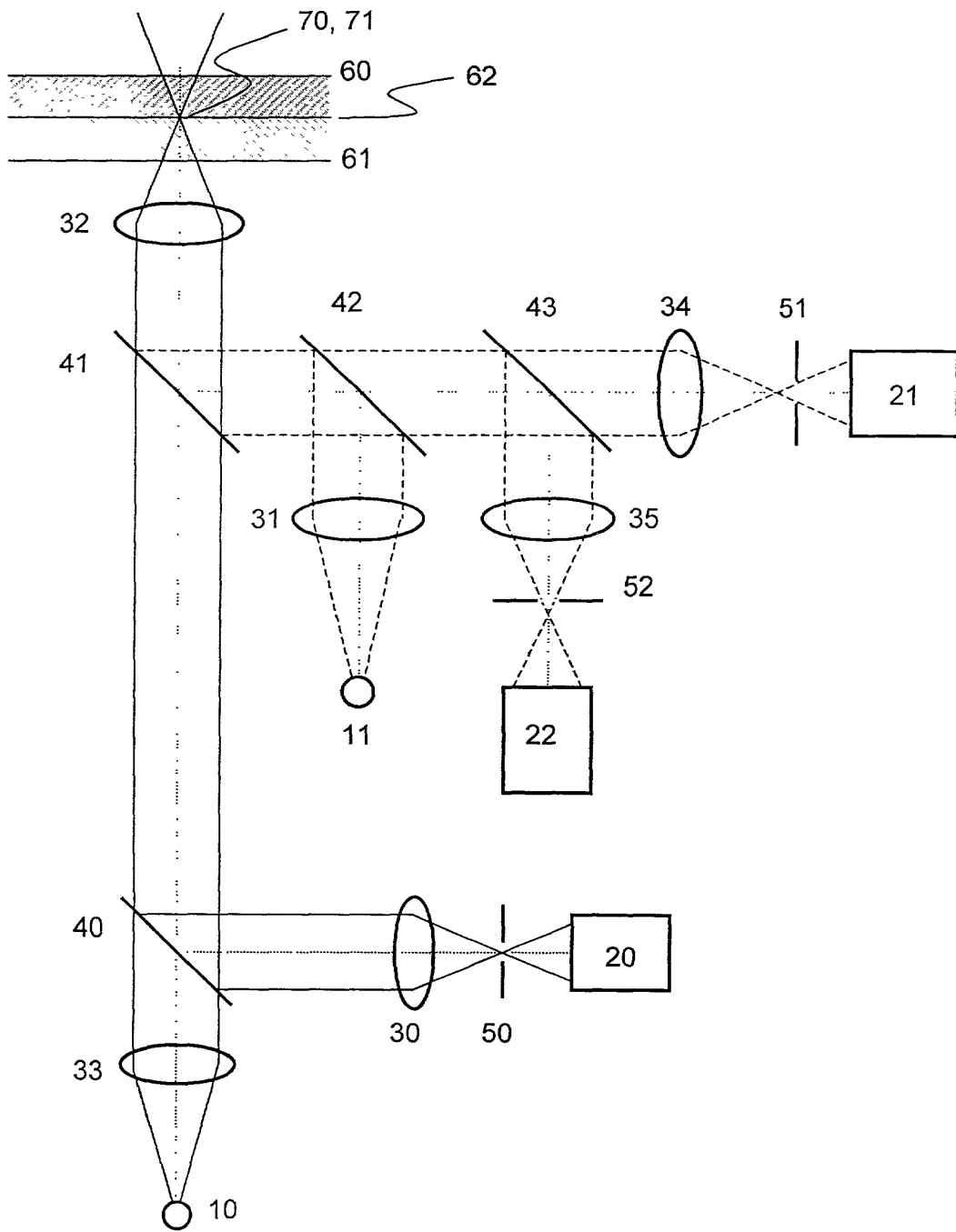

Figur 4

09868845 090701

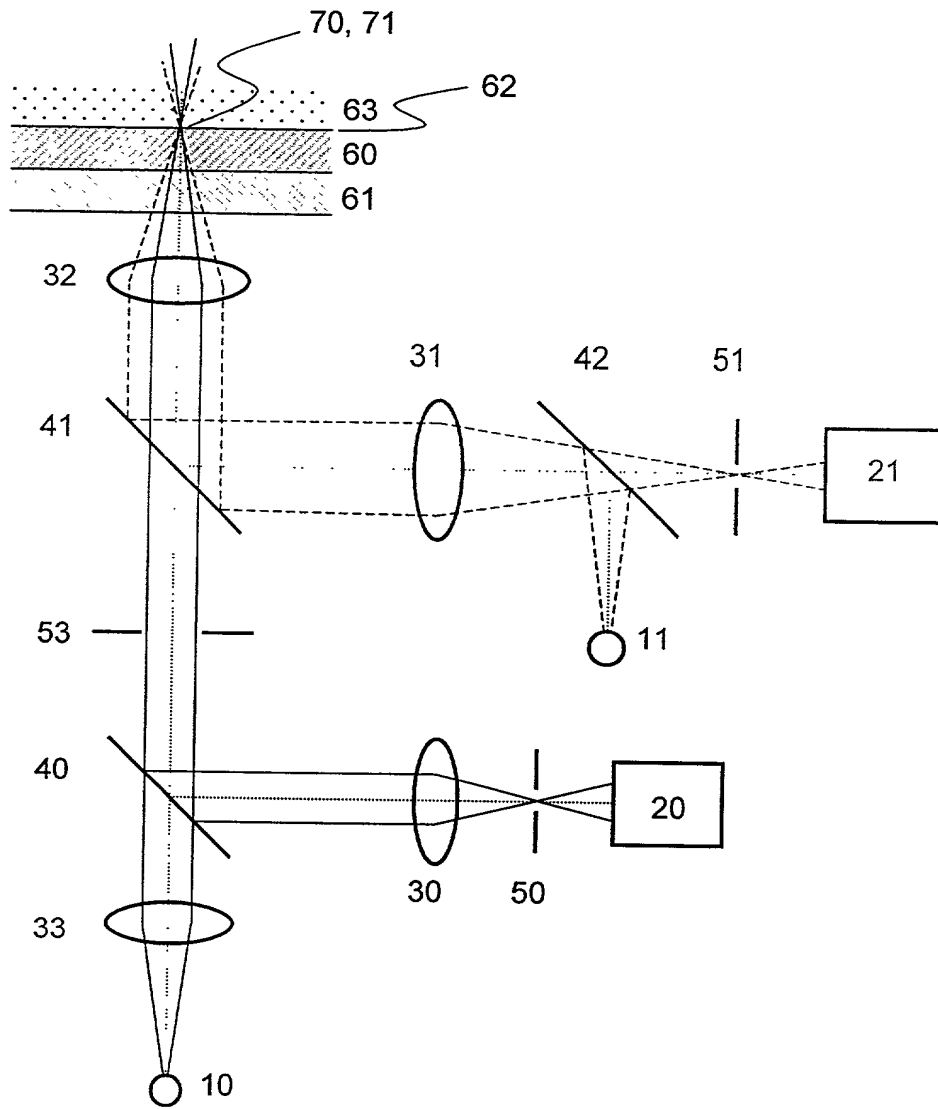

Figur 5

FOR OFFICIAL USE ONLY

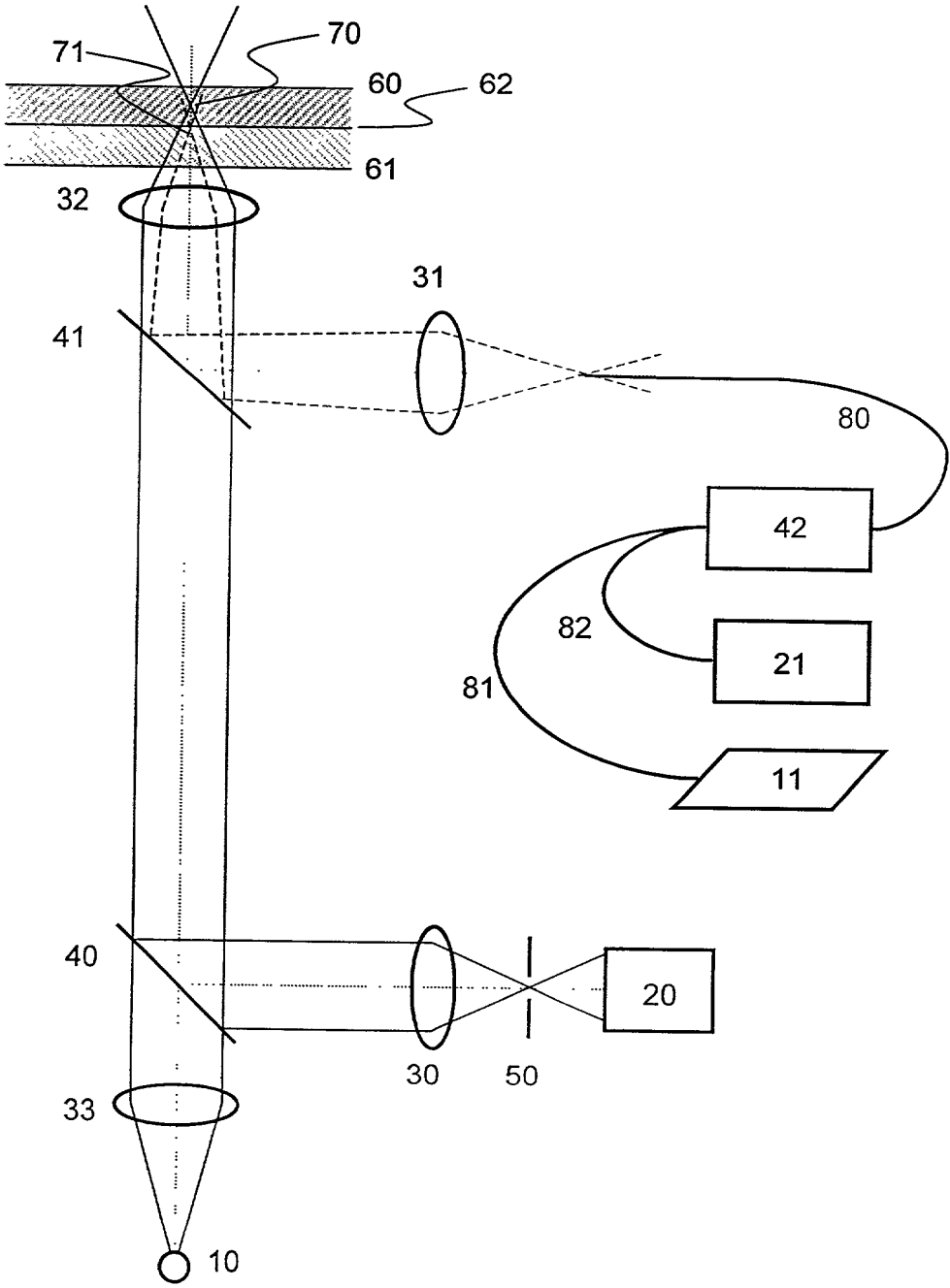

Figur 6

TOP SECRET

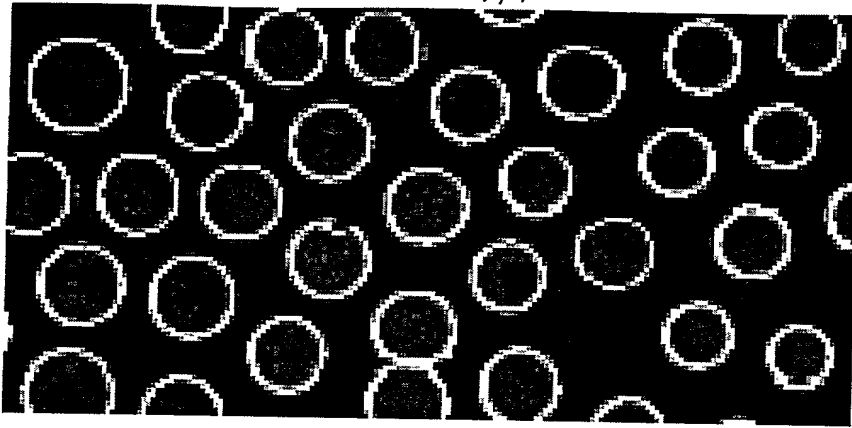

Figur 7a

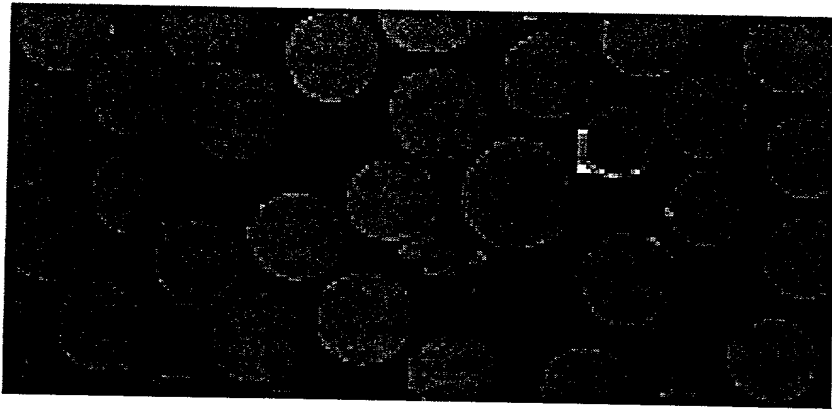

Figur 7b

09868845, 090701

BIRCH, STEWART, KOLASCH & BIRCH, LLP

COMBINED DECLARATION AND POWER OF ATTORNEY FOR PATENT AND DESIGN APPLICATIONS

ATTORNEY DOCKET NO.

PLEASE NOTE:
YOU MUST
COMPLETE THE
FOLLOWING:

As a below named inventor, I hereby declare that: my residence, post office address and citizenship are as stated next to my name; that I verily believe that I am the original, first and sole inventor (if only one inventor is named below) or an original, first and joint inventor (if plural inventors are named below) of the subject matter which is claimed and for which a patent is sought on the invention entitled:*

Insert Title ➡ Scanning Microscopic Method Having High Axial Resolution

Check Box If
Appropriate -
For Use Without
Specification
Attached

the specification of which is attached hereto unless the following box is checked:
 was filed on _____ as United States Application Number _____ or PCT International Application Number PCT/EP99/10142 filed on December 20, 1999 and was amended on _____ (if applicable).

I hereby state that I have reviewed and understand the contents of the above identified specification, including the claims, as amended by any amendment referred to above.

I acknowledge the duty to disclose information which is material to patentability as defined in Title 37, Code of Federal Regulations, §1.56.

I do not know and do not believe the same was ever known or used in the United States of America before my or our invention thereof, or patented or described in any printed publication in any country before my or our invention thereof, or more than one year prior to this application, that the same was not in public use or on sale in the United States of America more than one year prior to this application, that the invention has not been patented or made the subject of an inventor's certificate issued before the date of this application in any country foreign to the United States of America on an application filed by me or my legal representatives or assigns more than twelve months (six months for designs) prior to this application, and that no application for patent or inventor's certificate on this invention has been filed in any country foreign to the United States of America prior to this application by me or my legal representatives or assigns, except as follows.

I hereby claim foreign priority benefits under Title 35, United States Code, §119 (a)-(d) of any foreign application(s) for patent or inventor's certificate listed below and have also identified below any foreign application for patent or inventor's certificate having a filing date before that of the application on which priority is claimed:

Insert Priority
Information
(if appropriate)

Prior Foreign Application(s)			Priority	Claimed
<u>60/113,478</u>	<u>USA</u>	<u>December 21, 1998</u>	<input checked="" type="checkbox"/>	<input type="checkbox"/>
(Number)	(Country)	(Month/Day/Year Filed)	Yes	No
<u>98 124 314.0</u>	<u>Europe</u>	<u>December 21, 1998</u>	<input checked="" type="checkbox"/>	<input type="checkbox"/>
(Number)	(Country)	(Month/Day/Year Filed)	Yes	No
<u>198 60 549.8</u>	<u>Germany</u>	<u>December 21, 1998</u>	<input checked="" type="checkbox"/>	<input type="checkbox"/>
(Number)	(Country)	(Month/Day/Year Filed)	Yes	No
_____ (Number)	_____ (Country)	_____ (Month/Day/Year Filed)	<input type="checkbox"/>	<input type="checkbox"/>
_____ (Number)	_____ (Country)	_____ (Month/Day/Year Filed)	Yes	No
_____ (Number)	_____ (Country)	_____ (Month/Day/Year Filed)	<input type="checkbox"/>	<input type="checkbox"/>
_____ (Number)	_____ (Country)	_____ (Month/Day/Year Filed)	Yes	No

I hereby claim the benefit under Title 35, United States Code, § 119(e) of any United States provisional application(s) listed below.

(Application Number)	(Filing Date)
(Application Number)	(Filing Date)

All Foreign Applications, if any, for any Patent or Inventor's Certificate Filed More Than 12 Months (6 Months for Designs) Prior To The Filing Date of This Application:

Country	Application No	Date of Filing (Month/Day/Year)

I hereby claim the benefit under Title 35, United States Code, §120 of any United States application(s) listed below and, insofar as the subject matter of each of the claims of this application is not disclosed in the prior United States application in the manner provided by the first paragraph of Title 35, United States Code, §112, I acknowledge the duty to disclose information which is material to patentability as defined in Title 37, Code of Federal Regulations, §1.56 which became available between the filing date of the prior application and the national or PCT international filing date of this application:

(Application Number)	(Filing Date)	(Status — patented, pending, abandoned)
(Application Number)	(Filing Date)	(Status — patented, pending, abandoned)

*NOTE: Must be completed.

I hereby appoint the following attorneys to prosecute this application and/or an international application based on this application and to transact all business in the Patent and Trademark Office connected therewith and in connection with the resulting patent based on instructions received from the entity who first sent the application papers to the attorneys identified below, unless the inventor(s) or assignee provides said attorneys with a written notice to the contrary:

RAYMOND C. STEWART (Reg. No. 21,066)
 JOSEPH A. KOLASCH (Reg. No. 22,463)
 JAMES M. SLATTERY (Reg. No. 28,380)
 CHARLES GORENSTEIN (Reg. No. 29,271)
 LEONARD R. SVENSSON (Reg. No. 30,330)
 MARC S. WEINER (Reg. No. 32,181)
 JOE MCKINNEY MUNCY (Reg. No. 32,334)
 C. JOSEPH FARACI (Reg. No. 32,350)

TERRELL C. BIRCH (Reg. No. 19,382)
 ANTHONY L. BIRCH (Reg. No. 26,122)
 BERNARD L. SWEENEY (Reg. No. 24,448)
 MICHAEL K. MUTTER (Reg. No. 29,680)
 GERALD M. MURPHY, JR. (Reg. No. 28,977)
 TERRY L. CLARK (Reg. No. 32,644)
 ANDREW D. MEIKLE (Reg. No. 32,868)
 ANDREW F. REISH (Reg. No. 33,443)

16

Send Correspondence to: **BIRCH, STEWART, KOLASCH AND BIRCH, LLP**

P.O. Box 747
Falls Church, Virginia 22040-0747
Telephone: (703) 205-8000
Facsimile: (703) 205-8050

PLEASE NOTE:
 YOU MUST
 COMPLETE THE
 FOLLOWING:

I hereby declare that all statements made herein of my own knowledge are true and that all statements made on information and belief are believed to be true; and further that these statements were made with the knowledge that willful false statements and the like so made are punishable by fine or imprisonment, or both, under Section 1001 of Title 18 of the United States Code and that such willful false statements may jeopardize the validity of the application or any patent issued thereon.

Full Name of First or Sole Inventor:

Insert Name of Inventor
 Insert Date This Document Is Signed

Insert Residence
 Insert Citizenship

Insert Post Office Address

Full Name of Second Inventor, if any:

see above

Full Name of Third Inventor, if any:

see above

Full Name of Fourth Inventor, if any:

see above

Full Name of Fifth Inventor, if any:

see above

GIVEN NAME	FAMILY NAME	INVENTOR'S SIGNATURE	DATE*
Juergen Rolf	MUELLER	<i>Juergen Mueller</i>	7/4/01
Residence (City, State & Country)		CITIZENSHIP	
22081 Hamburg, Germany		22529 Hamburg	German
POST OFFICE ADDRESS (Complete Street Address including City, State & Country)			
Glueckstrasse 4a, 22081 Hamburg, Germany 22529 Hamburg DE			
GIVEN NAME	FAMILY NAME	INVENTOR'S SIGNATURE	DATE*
Residence (City, State & Country)		CITIZENSHIP	
POST OFFICE ADDRESS (Complete Street Address including City, State & Country)			
GIVEN NAME	FAMILY NAME	INVENTOR'S SIGNATURE	DATE*
Residence (City, State & Country)		CITIZENSHIP	
POST OFFICE ADDRESS (Complete Street Address including City, State & Country)			
GIVEN NAME	FAMILY NAME	INVENTOR'S SIGNATURE	DATE*
Residence (City, State & Country)		CITIZENSHIP	
POST OFFICE ADDRESS (Complete Street Address including City, State & Country)			

*Note: Must be completed
 - date this document is
 gned.